

QBL

SYSTEM
BIKE-UNIT PRO MODULAR

Dry it. Store it. Use it.

FUNCTIONAL, VERSATILE,
PRECISION-ENGINEERED BIKE STORAGE SYSTEM
IN A MODULAR FORM



The Bike-Unit PRO Modular is a professional rack designed for storing multiple bikes of different categories and sizes in series. The L-shaped steel structure has the form of a tapered trough on the inside in which the front wheel of the bike is wedged and immobilised. For an even firmer hold on the bike, the PRO model is equipped with a profiled rotating clamping element, which additionally grips the wheel from the frame side. The finely tuned grip system is based on 3-point contact support, which ensures stability, safe storage and extremely versatile use (from road bikes, through the Trail category, the widest electric bikes, to DH models). The maximum width of the tyre that fits in the rack is 80mm.

The Bike-Units PRO Modular are mounted in series (perpendicular or at max 22° angle) on two special steel rails, at any distance from each other – depending on the

width of the stored bikes. To increase storage capacity by limiting the spacing between bikes, the High model has been designed. It is 10cm higher and it should be used with the regular model alternately.

The Bike-Unit PRO Modular rack system provides an integrated storage system for larger numbers of bicycles – whether in shops, bike rentals, depots or in the private spaces of advanced and professional cyclists.

The product is made of high-quality powder-coated galvanised steel, guaranteeing durability and resistance to corrosion. Thanks to its tailor-made few-piece design, the system can be assembled quickly and intuitively.

BIKE-UNIT PRO MODULAR

Q-BK-UNPRO-M-210



TECHNOLOGIES:

- **Storage for professionals as well as for shops and bike depots**
Multiple stands mounted in series on special steel rails (perpendicularly or at max 22° angle)
- **High version for even greater storage capacity**
Additional model higher by 10cm to decrease spacing between bikes
- **Rotating clamping element for an even tighter hold**
Additional immobilisation of the front wheel
- **3-point bike holding system**
Efficient storage due to secure front wheel support
- **Extremely versatile use**
Adapted to various bike models and tyre widths (max. 80mm)
- **Double protection**
Galvanized steel and powder coating



BIKE-UNIT **PRO** MODULAR

Q-BK-UNPRO-M-210

TECHNICAL FEATURES:

BIKE-UNIT **PRO** MODULAR

Q-BK-UNPRO-M-210

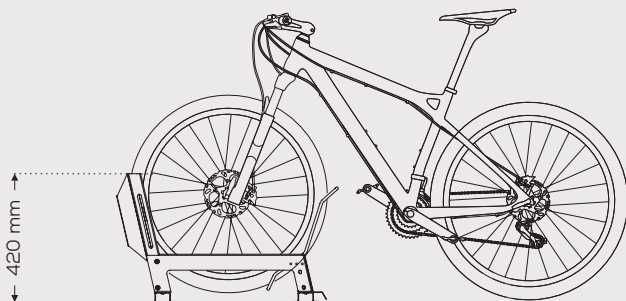

BIKE-UNIT **HIGH PRO** MODULAR

Q-BK-UNHPRO-M-210

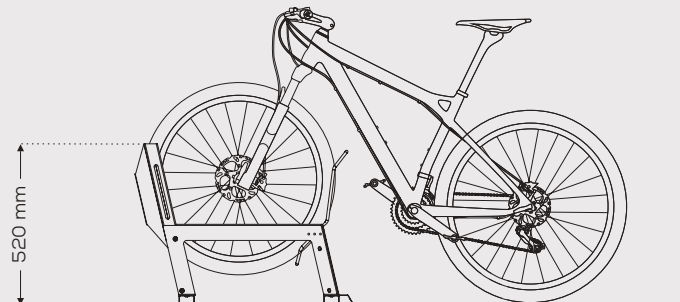

Maximum tire width: 80 mm

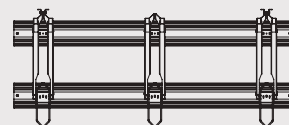
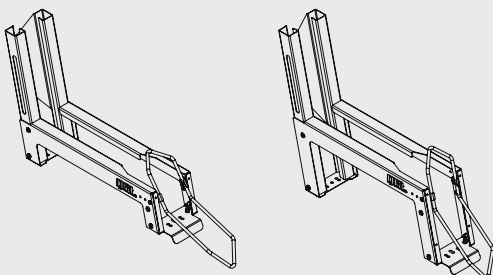

Perpendicular position



Angled position 22°

QBL

STORAGE WITH THE UNITS OF THE SAME HEIGHT

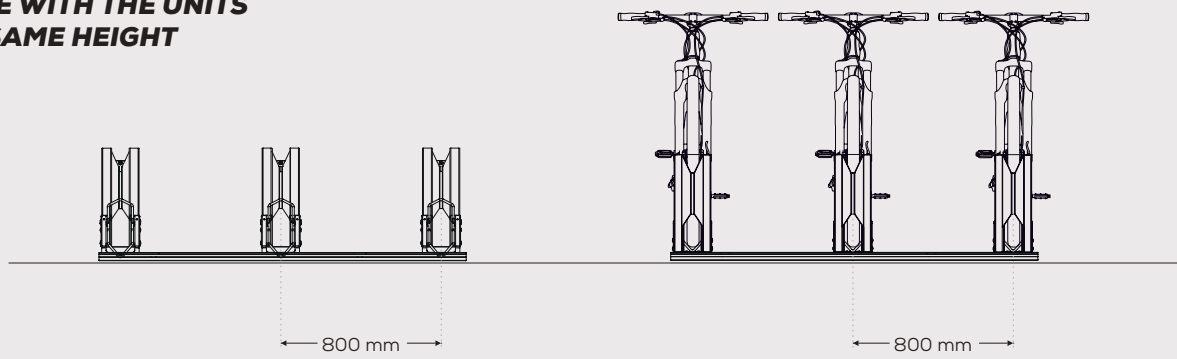

STORAGE WITH THE REGULAR AND THE HIGH UNITS ALTERNATELY

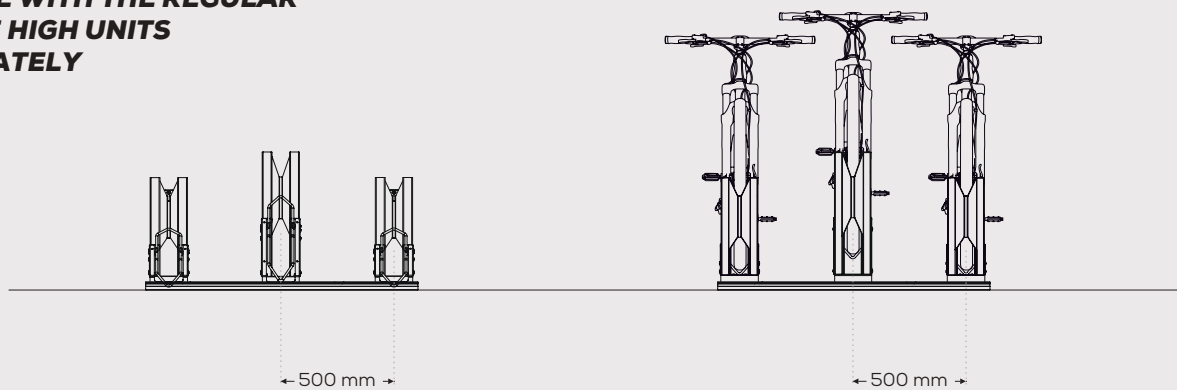

Dry it. Store it. Use it.